

---

---

# **WARWICK WIRELESS LIMITED**

---

---

## **X7306 PZT TELEMETRY LINK**

Data Sheet DS170-1

**WARWICK WIRELESS LIMITED**

THE MANOR, ASTON FLAMVILLE, LEICESTERSHIRE, LE10 3AQ ENGLAND  
TEL: +44 (0) 1455 233616 FAX: +44 (0) 1455 233179 WEB: [www.radiotelemetry.co.uk](http://www.radiotelemetry.co.uk)

## Introduction

This guide covers the Warwick Wireless Ltd Telemetry transmitter and receiver units. Used as a matched pair, these allow camera control telemetry signals to be sent via wireless link from standard camera control units over distances up to 1000m.

The units utilise a licence exempt frequency in the 458MHz range and fourteen channels are available within the band. The frequency channel of each box is printed on the PCB-mounted module box as follows:

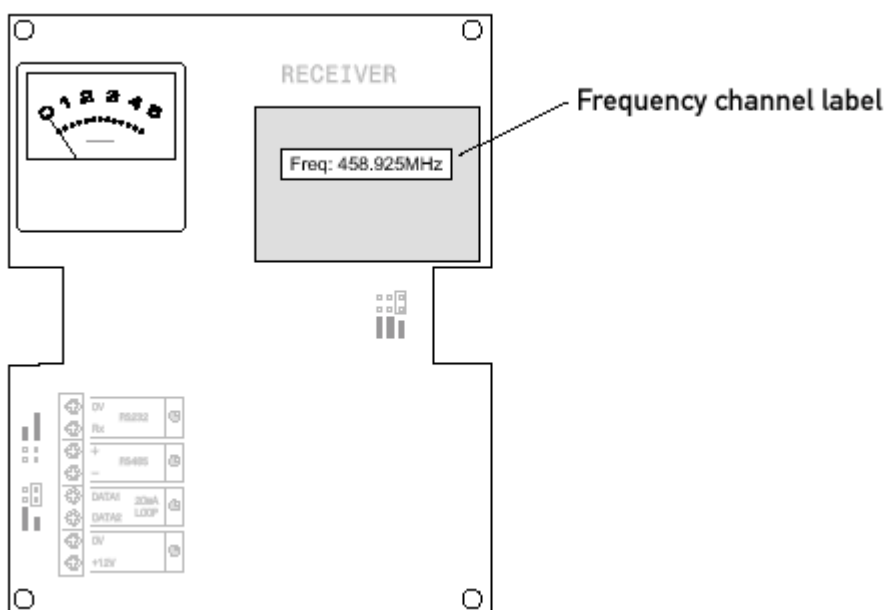

To offer maximum flexibility, the Warwick Wireless Telemetry system supports four different telemetry signal types:

- RS232
- RS485
- BBV 20mA current loop
- Baxall 20mA current loop

The Warwick Wireless Telemetry system is designed to work alongside the Warwick Wireless Microvision system which allows the CCTV video images to be transmitted by wireless link back to the controller.

## Tuning and signal checking

The Warwick Wireless Telemetry units include key features to assist in quick setup, commissioning and fault finding of the system.

### Tuning

The receiver unit includes a signal meter to assist in quickly locating the optimum antenna placement. Use the meter to find the peak input signal.

### Signal checking

Both the receiver and transmitter units include LED indicators for each signal type as well as the power input. The indicators for the currently used signal type should flash on the transmitter and receiver units when data is being transferred.

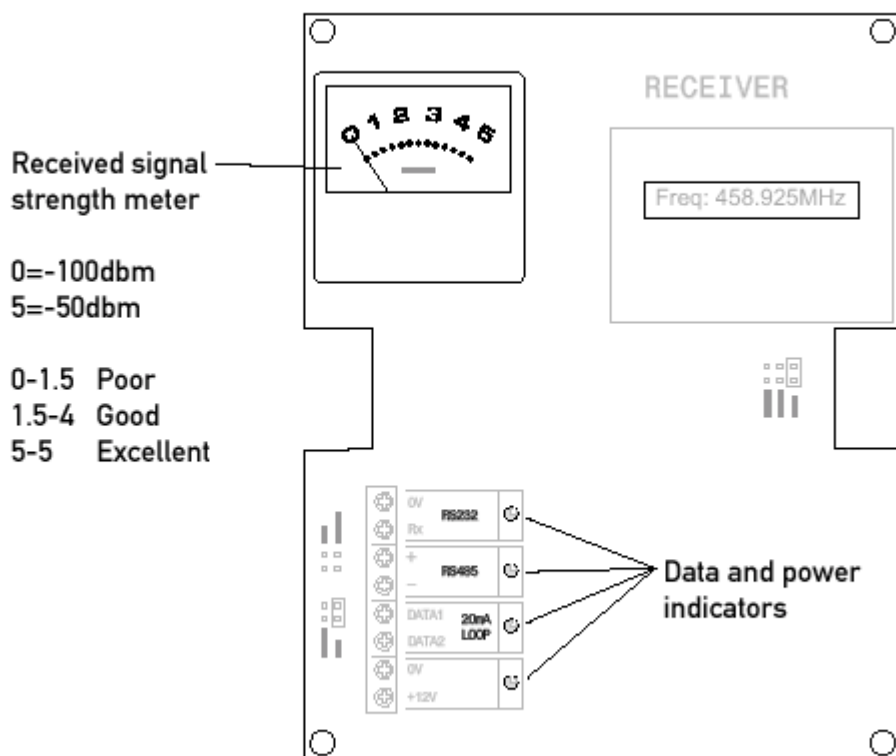

## RS232

This connection method provides a simplex RS-232 link

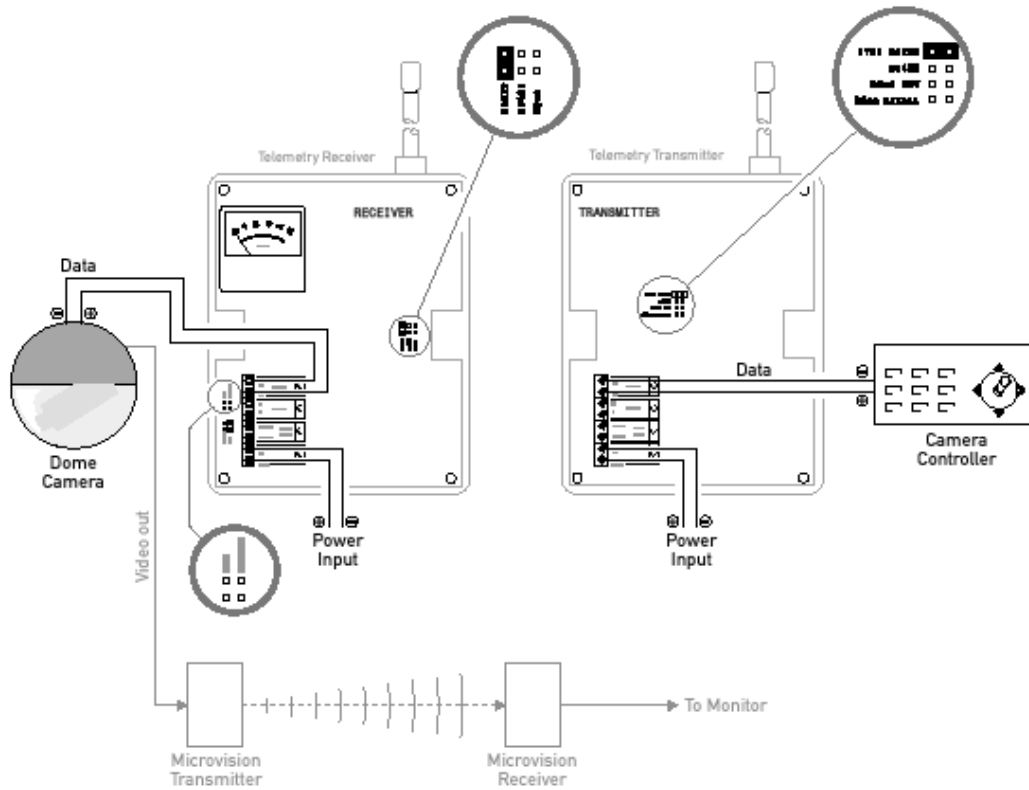

### To ensure correct operation:

- Ensure that the polarities of the controller and camera connections are correct.
- Set the jumpers on the transmitter and receiver PCBs to the RS232 settings.
- Connect 12VDC 500mA supplies to the Power Input terminals on both the transmitter and receiver PCBs.

Note: *This is a simplex connection with no positional feedback.*

The RS232 LED indicator will show:

- Regular flashing to indicate data processing.
- Random flashing indicates interference or transmitter not on.
- Static on or off indicates no data present.

Note: *The RS232 LED will remain ON when RS232 connections are not used.*

If a duplex is required, then two links must be used on different frequencies.

## RS485

This connection method provides a simplex RS-485 link.

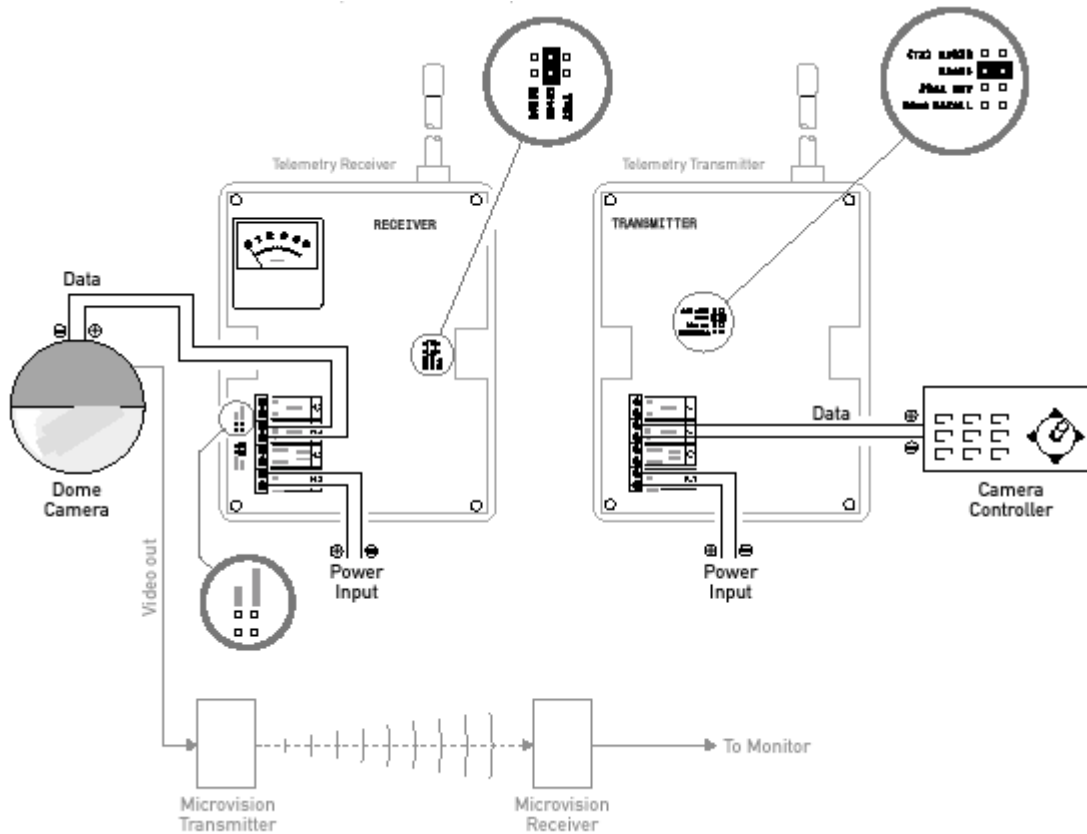

### To ensure correct operation:

- Ensure that the polarities of the controller and camera connections are correct.
- Set the jumpers on the transmitter and receiver PCBs to their RS485 settings.
- For a VCL dome camera, set the VCL jumper. For any other manufacturer's dome camera, set the Normal jumper.
- Connect 12 VDC 500mA supplies to the Power Input terminals on both the transmitter and receiver PCBs.

### If correct operation does not occur:

- The Polarities of the controller input and camera output must match. If operation does not occur, swap either the camera or controller connections over and test again.

The RS485 LED indicator will show:

- Regular flashing to indicate data processing.
- Random flashing indicates interference or transmitter not on.
- Static on or off indicates no data present.

Note: *The RS232 LED will remain ON when RS232 connections are not used.*

If a duplex link is required, then two links must be used on different frequencies.

## BBV 20mA Current Loop

This connection method provides a 20mA current loop link suitable for use with BBV-type equipment.

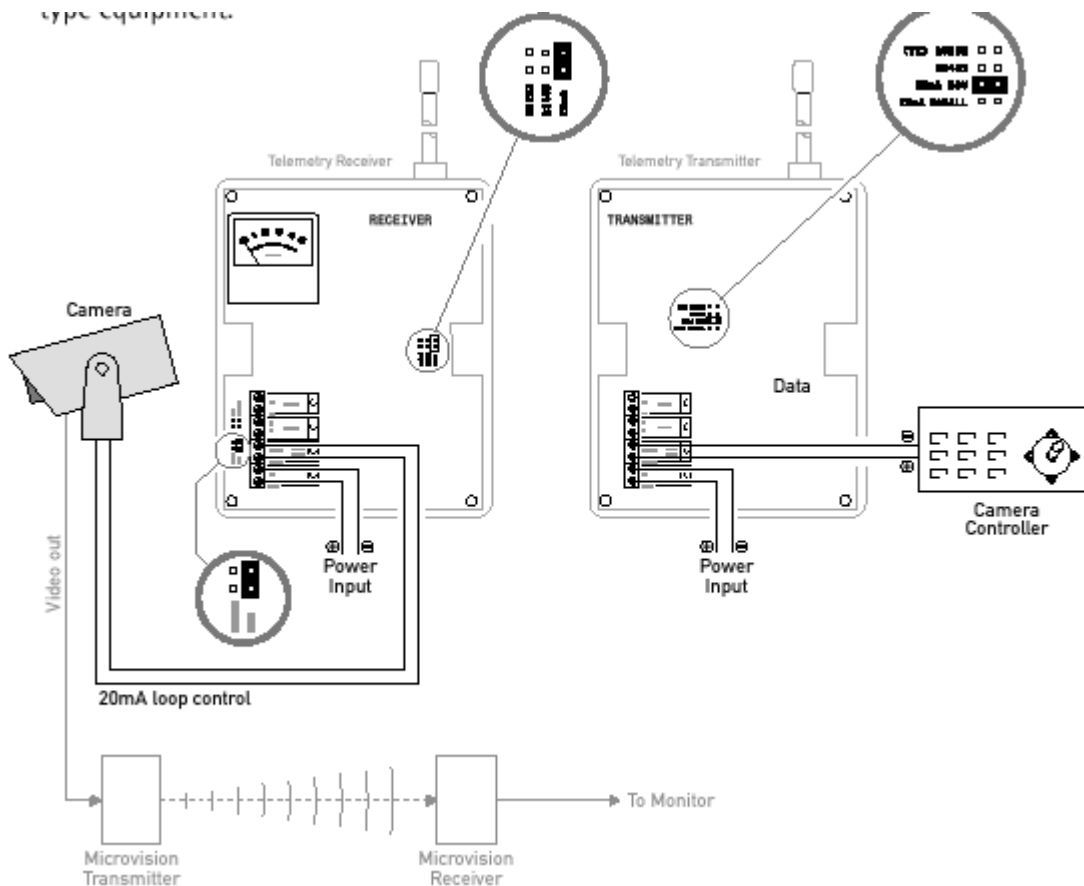

### To ensure correct operation:

- Set the jumper on the transmitter PCB to the 20mA BBV setting.
- Set the jumpers on the receiver PCB to their BBV and 20mA settings.
- Connect 12VDC 500mA supplies to the Power Input terminals on both the transmitter and receiver PCBs.

The 20mA Loop LED indicator will show:

- Regular flashing to indicate data processing.
- Random flashing indicates interference or transmitter not on:
- Static on or off indicates no data present.

Note: *The RS232 LED will remain ON when RS232 connections are used.*

### If correct operation does not occur.

- The camera controller input wires to the Telemetry transmitter are polarised. If operation does not occur, swap the two wires over and test again.

## Baxall 20mA Current Loop

This connection method provides a 20mA current loop link suitable for use with Baxall-type equipment.

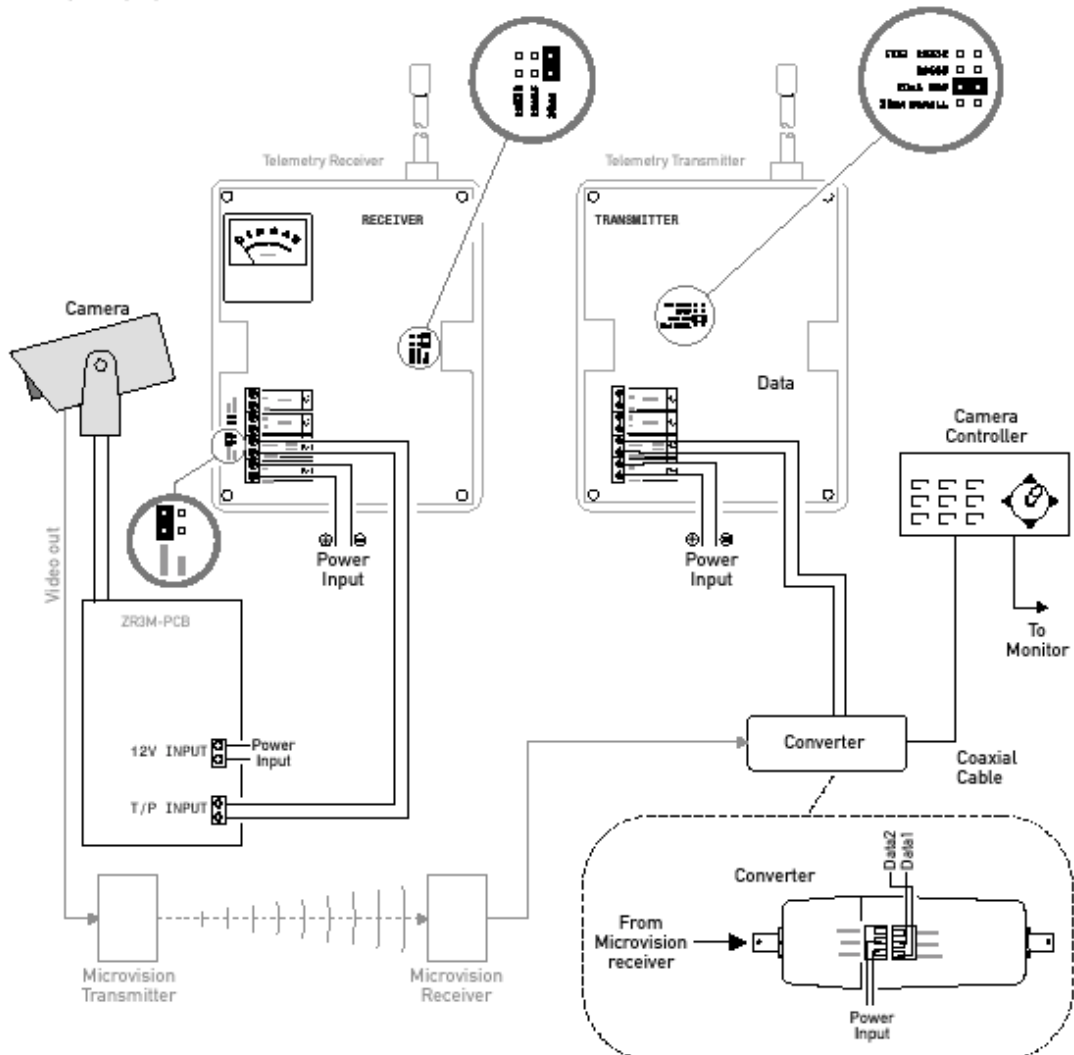

### To ensure correct operation:

- Set the jumper on the transmitter PCB to the 20mA BAXEL setting.
- Set the jumpers on the receiver PCB to the BAXEL and 20mA settings.
- Connect 12VDC 500mA supplies to the Power Input terminals on both the transmitter and receiver PCBs.

## Mounting the Units

The Telemetry transmitter and receiver units are provided with unidirectional whip antennae. To obtain optimum signal strength, the transmitter and receiver antennae should be unrestricted. For instance, if the box is mounted onto a wall, where possible, the antenna should stand clear of the wall.

When the Telemetry system is being used in conjunction with the Microvision wireless video link (or another similar system), the Telemetry unit should be placed no closer than 1 metre from the Microvision antenna.

The Telemetry unit should never be placed in the line of sight between the Microvision antennae.

If the Telemetry and Microvision systems must be placed in close proximity, place the Telemetry units above the Microvision boxes.

**IMPORTANT: The telemetry transmitter should never be powered without the correct antennae being fitted.**

## Long range antennae

For long range applications (between 1 –5 km) use X605 High-gain YAGI antenna.

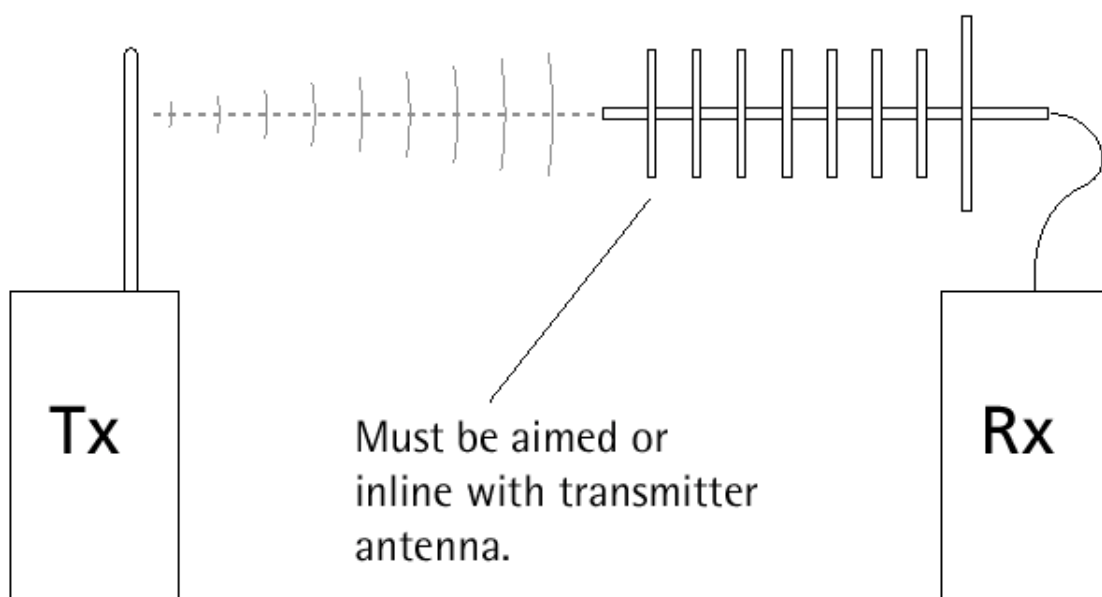

HELP LINE NUMBER +44 (0) 1455 233616

**WARNING**

Information contained in this document is believed to be accurate, however no representation or warranty is given and Warwick Wireless Ltd. assumes no liability with respect to the accuracy of such information. Use of Warwick Wireless's products as critical components in life support systems is not authorised except with express written approval from Warwick Wireless Ltd. Further Warwick Wireless Limited reserve the right to change the design or specification of the X8200 Radio Modem without notification and has no responsibility for the installation and operation of the equipment by third parties.

All documentation and software are copyright.