

Features

- Operation on 434.075, 868.40 and 914.5 MHz
- X2011 version includes integrated pcb loop antenna (434 & 868 MHz versions)
- Double RF filtering = High Reliability RF Link
- Data rates to 20 kbps (Wide-band 64 kbps version available to order)
- -112 dBm receiver sensitivity (434 version)
- CD and RSSI outputs
- Crystal stabilised accurate RF, hence narrower BW filter utilised
- Results in over 300m range
- EN 300 220-1, 300 683 & FCC compliant
- Immune to Tetra and High power Radio Amateur Repeater Stations

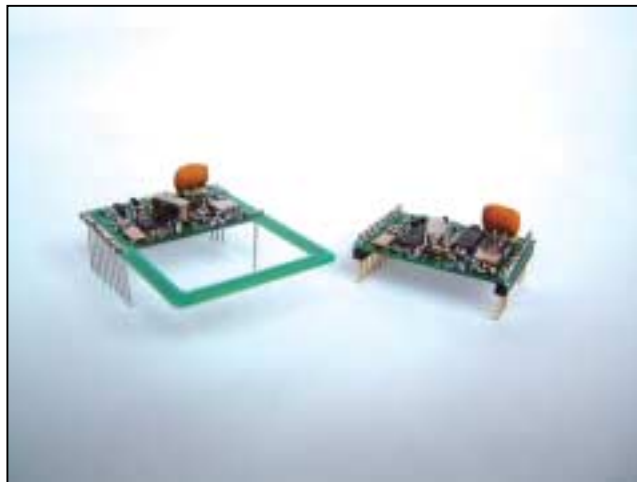

Applications

- EPOS Terminals
- Wireless Networking
- Domestic And Commercial Wireless Security Systems
- Panic Attack Facility
- Remote Control For Cranes Etc

General Description

The X2010 radio transceiver module was designed to provide reliable wireless operation at moderate data rates for use throughout the world. Its unique features of narrower RF channel bandwidths and hence high interference rejection capability at SAW module prices make the X2010 the ideal choice for next generation applications.

Available at several frequency options, these modules have been designed to provide a reliable wire free link within the presence of other interference at the same frequency, accounting for the increased traffic from other legal users of the radio spectrum

WARWICK WIRELESS LIMITED

THE MANOR, ASTON FLAMVILLE, LEICESTERSHIRE, LE10 3AQ ENGLAND

TEL: +44 (0) 1455 233616 FAX: +44 (0) 1455 233179 WEB: www.radiotelemetry.co.uk

Absolute Maximum Ratings

Operating temperature: -25°C to +55°C
Storage temperature: -40°C to +100°C

Supply Voltage (pin 3) 6V
Data input (pin 5) $V_{cc} + 0.3V$
RF Input 0dBm

Electrical Characteristics:

Performance data measured at 20°C and +5 volt supply and RF = 434.075 MHz.

| | pin | min. | typ. | max. | units | notes |
|---|-------|---------|-------|---------|-------|-------|
| DC LEVELS | | | | | | |
| Supply voltage | 17 | 4.5 | 5 | 5.5 | V | |
| Supply current (receiver enabled) | 17 | | 7 | | mA | |
| Supply current (transmitter enabled) | 17 | | 8 | | mA | |
| Leakege current with Vcc connected | | | | 1 | uA | |
| Data input/output high | 12,14 | 0.7xVcc | | Vcc | V | |
| Data input/output low | 12,14 | 0 | | 0.0xVcc | V | |
| RF | | | | | | |
| Receiver sensitivity (12 dB SINAD on AF output) | 13 | | -112 | | dBm | |
| Image rejection | | | 50 | | dB | |
| RF power out (transmitter) | | | 10 | | mW | |
| FM Deviation | | | +/-10 | | KHz | |
| Initial frequency accuracy | | | ±100 | | Hz | |
| Overall frequency accuracy | | | +/-2 | | KHz | |
| Max R.F. input to receiver | | | 0 | | dBm | |
| E.M.C. | | | | | | |
| Spurious responses upto 1GHz | | | <-36 | | dB | |
| LO leakage, conducted | | | <60 | | dBm | |
| LO leakage, radiated | | | <60 | | dBm | |
| DYNAMIC TIMING | | | | | | |
| RX enable to valid RSSI / CD | | | | | mS | |
| RX enable to stable receiver data out | | | 5 | | mS | |
| TX enable to full RF out | | | 5 | | mS | |
| Minimum data pulse width | | | 50 | | uS | |
| Data Bit rate | | 50 | | 20000 | bps | 2 |

Notes

- Over full operating temperature range
- 1 Hz = 2 bps

WARWICK WIRELESS LIMITED

THE MANOR, ASTON FLAMVILLE, LEICESTERSHIRE, LE10 3AQ ENGLAND

TEL: +44 (0) 1455 233616 FAX: +44 (0) 1455 233179 WEB: www.radiotelemetry.co.uk

X2010 Mechanical Detail

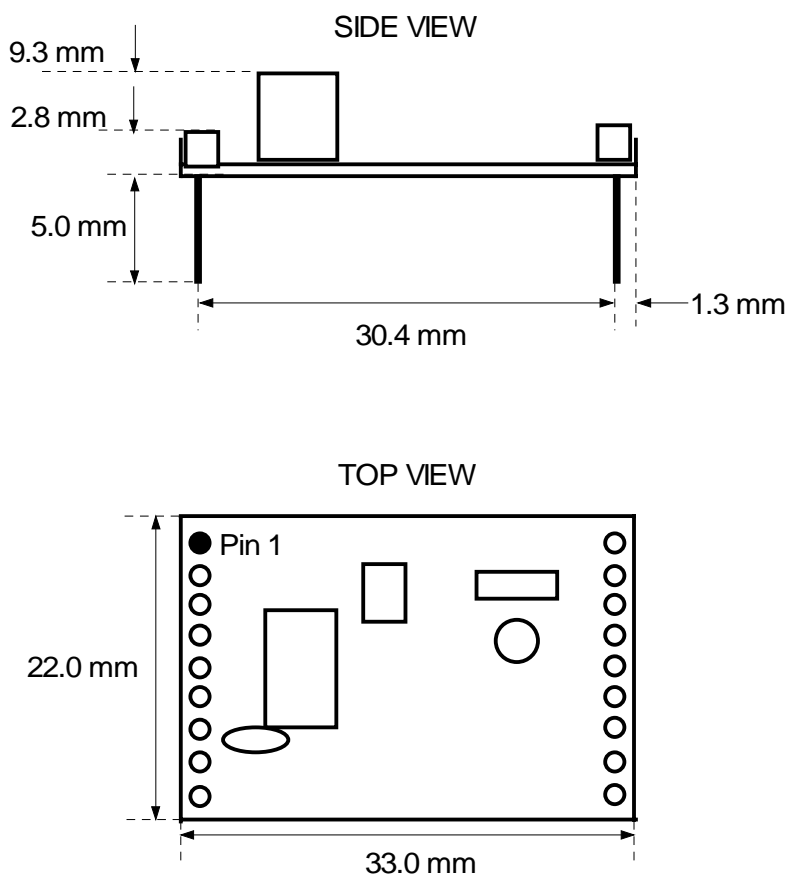

Notes

1. Recommended PCB hole diameter to accommodate the connecting pins = 1.2mm
2. Pins are on a 2.54mm pitch
3. Pins 4,5,6 and 7 are internally floating (unconnected)

WARWICK WIRELESS LIMITED

THE MANOR, ASTON FLAMVILLE, LEICESTERSHIRE, LE10 3AQ ENGLAND

TEL: +44 (0) 1455 233616 FAX: +44 (0) 1455 233179 WEB: www.radiotelemetry.co.uk

X2011 Mechanical Detail

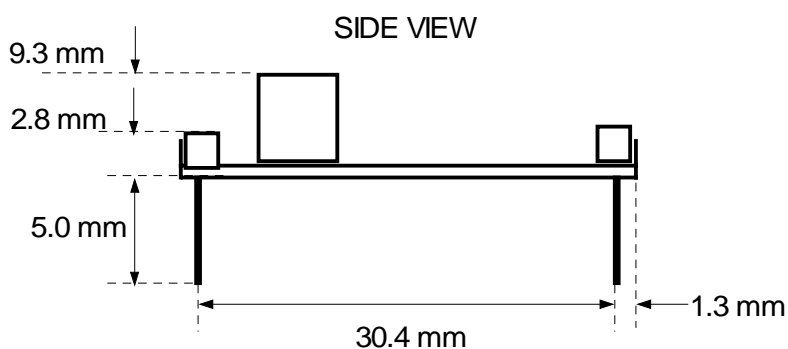
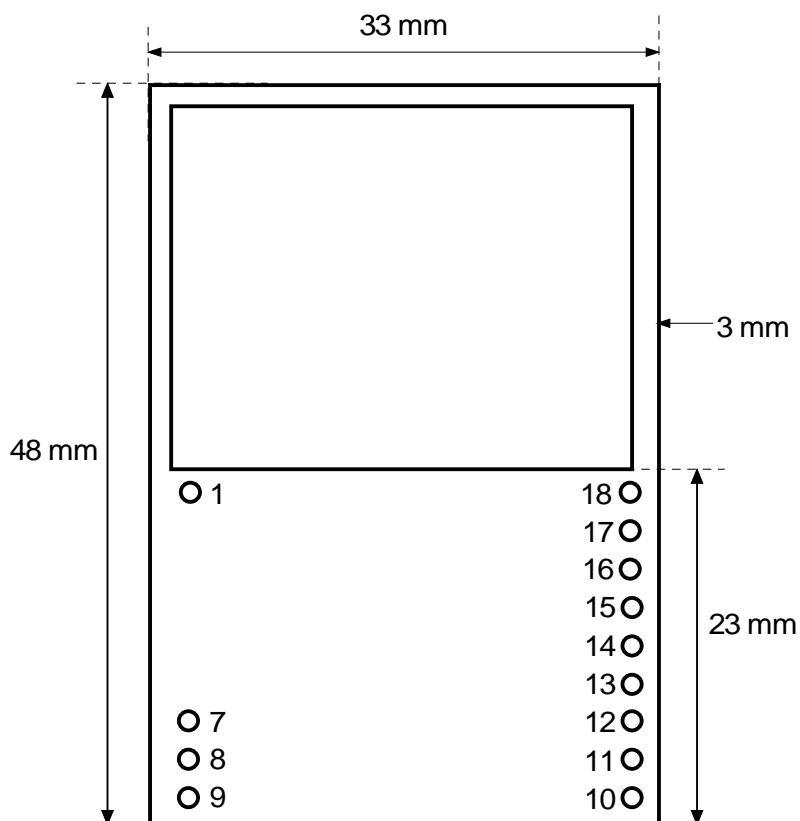

Notes

1. Recommended PCB hole diameter to accommodate the connecting pins = 1.2mm
4. Pins are on a 2.54mm pitch

WARWICK WIRELESS LIMITED

THE MANOR, ASTON FLAMVILLE, LEICESTERSHIRE, LE10 3AQ ENGLAND

TEL: +44 (0) 1455 233616 FAX: +44 (0) 1455 233179 WEB: www.radiotelemetry.co.uk

Pin Functional Description

| Pin No. | Description | Details |
|---------|--------------|---|
| 1 & 3 | RF Ground | Ideally connected to antenna ground plane. |
| 2 | Antenna | Nominal 50 ohm input/output impedance capacitively isolated from internal circuit. |
| 4,5,6 | NC | Not connected internally on X2010 module. |
| 7 | NC Ground | X2010: This is unconnected X2011: RF Ground. |
| 8 | RSSI | Receiver signal strength indicator. DC voltage proportional to the RF signal strength being received. |
| 9,10,18 | Ground | Supply ground points. |
| 11 | CD | Carrier detect output, active low. |
| 12 | RxD | Receiver data output (CMOS logic out) |
| 13 | AF | Audio frequency output. |
| 14 | TxD | Transmitter data input. |
| 15 | Tx Enable | Active low, applying Vcc disables the transmitter. |
| 16 | Rx Enable | Active low, applying Vcc places the receiver in sleep mode. |
| 17 | Vcc | Supply voltage. |

State Table

| Tx (pin 15) | Rx (pin 16) | Mode |
|-------------|-------------|--|
| 1 | 1 | Power down mode. Supply current <1uA |
| 1 | 0 | Receiver only enabled. Data, AF, CD and RSSI outputs valid. |
| 0 | 1 | Transmitter only enabled. Tx data input valid. |
| 0 | 0 | Tx and Rx enabled. This mode is to be avoided as damage to the module will eventually occur. |

RSSI Output

The RSSI output provides a dc voltage that is proportional to the RF signal strength picked up on the antenna (pin 2) port of the module.

The table below gives typical values of RSSI for varying degrees of RF signal strength applied

| RF Input (dBm) | RSSI (V) |
|----------------|----------|
| -105 | 0.82 |
| -100 | 0.88 |
| -90 | 1.12 |
| -80 | 1.43 |
| -70 | 1.75 |
| -60 | 2.06 |
| -50 | 2.36 |
| -40 | 2.57 |
| -30 | 2.6 |
| -20 | 2.6 |

WARWICK WIRELESS LIMITED

THE MANOR, ASTON FLAMVILLE, LEICESTERSHIRE, LE10 3AQ ENGLAND

TEL: +44 (0) 1455 233616 FAX: +44 (0) 1455 233179 WEB: www.radiotelemetry.co.uk

Antenna Design

The design and positioning of the antenna is as crucial as the module performance itself in achieving a good wireless system range. The following will assist the designer in maximising system performance.

The antenna should be kept as far away from sources of electrical interference as physically possible. If necessary, additional power line decoupling capacitors should be placed close to the module.

The antenna 'hot end' should be kept clear of any objects, especially any metal as this can severely restrict the efficiency of the antenna to receive power. Any earth planes restricting the radiation path to the antenna will also have the same effect.

Best range is achieved with either a straight piece of wire, rod or PCB track @ $\frac{1}{4}$ wavelength (15.5cm @ 433.92MHz). Further range may be achieved if the $\frac{1}{4}$ wave antenna is placed perpendicular in the middle of a solid earth plane measuring at least 16cm radius. In this case, the antenna should be connected to the module via some 50 ohm characteristic impedance coax

Part Numbers

| Part Number | Description |
|-------------|---|
| X2010-434 | Narrow Band Transceiver 434.075MHz |
| X2011-434 | Narrow Band Transceiver 434.075MHz Integral Antenna |
| X2010-868 | Narrow Band Transceiver 868.4MHz |
| X2011-868 | Narrow Band Transceiver 868.4MHz Integral Antenna |
| X2010-915 | Narrow Band Transceiver 914.5MHz |
| X2011-915 | Narrow Band Transceiver 914.5MHz Integral Antenna |

Information contained in this document is believed to be accurate, however no representation or warranty is given and no liability is assumed by Warwick Wireless Ltd. With respect to the accuracy of such information. Use of Warwick Wireless as critical components in life support systems is not authorised except with express written approval from Warwick Wireless Ltd.

WARWICK WIRELESS LIMITED

THE MANOR, ASTON FLAMVILLE, LEICESTERSHIRE, LE10 3AQ ENGLAND
TEL: +44 (0) 1455 233616 FAX: +44 (0) 1455 233179 WEB: www.radiotelemetry.co.uk