

Features

- Miniature Module
- QM Modulation
- Optimal Range 1000m
- Operates Within 433 Licence Free Band
- 34 Channels Available
- Single Supply Voltage

Applications

- IN VEHICLE TELEMETRY SYSTEMS
- WIRELESS NETWORKING
- DOMESTIC AND COMMERCIAL WIRELESS SECURITY SYSTEMS
- PANIC ATTACK FACILITY

Transmitter

- ANALOGUE AND DIGITAL INPUTS
- 10mW RF OUTPUT POWER (100mW Optional)
- NARROW BAND CRYSTAL STABILISED
- SMALL FORM FACTOR

General Description

The QBT37-XXX and QBR37-XXX are miniature narrow band transmitter and receiver UHF radio modules, which enable the implementation of a simple telemetry link at data rates up to 20Kbits/s.

Available for operation between 433.075 and 434.725 MHz in 50KHz steps these modules give the possibility of 34 different frequency channels and are able to transmit at distances of up to 400m.

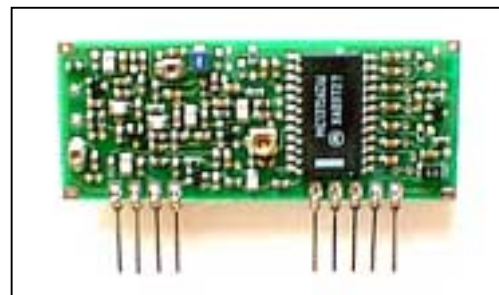
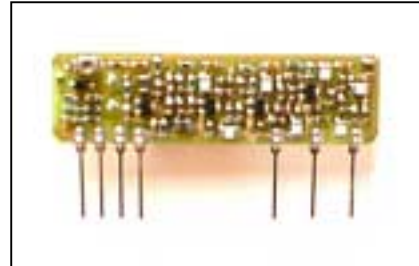

Receiver

- DATA & AF OUT
- CD IMPLEMENTED ON DATA OUTPUT
- RSSI OUTPUT
- SELECTIVE CERAMIC IF FILTERS

The QBT37-XXX and QBR37-XXX modules will suit one-to-one and multi-node wireless links in applications including building and car security, remote industrial process monitoring and computer networking. Because of their small size and low power requirements, both modules are ideal for use in portable battery powered wireless applications

Absolute Maximum Ratings: Transmitter

Operating temperature:	-10°C to +55°C
Storage temperature:	-40°C to +100°C
Supply Voltage (pin 3)	10V
Data input (pin 5)	10V

Electrical Characteristics: Transmitter

	pin	min.	typ.	max.	units	notes
DC LEVELS						
Supply voltage		4.5	5.0	5.5	Volts	
Current & RF POWER						
Supply current @ $V_{CC} = 5V$ (data low/high)			22		mA	1
RF output power @ $V_{CC} = 5V$			10		mW	1
RF & Data						
Channel separation			50		KHz	
Max Modulation frequency			10		KHz	
2 nd harmonic			66		dBc	1
Harmonics @ > 1GHz			46		dBc	1
Initial frequency accuracy			1		KHz	
Overall frequency accuracy			5		KHz	
FM deviation (\pm)			7		KHz	
Modulation bandwidth @ -3dB			10		KHz	
Modulation distortion (THD)					%	
Power up time to full RF			10		μ s	
Data rate				20000	bits/s	
Data pulse width		50		10000	μ s	

Note 1: measured into a 50 Ω impedance

Absolute Maximum Ratings: Receiver

Operating temperature:	-10°C to +55°C
Storage temperature:	-40°C to +100°C
Supply Voltage	10V
Data input	10V

Electrical Characteristics: Receiver

	pin	min.	typ.	max.	units	notes
DC LEVELS						
Supply voltage			5		V	
Supply current			14		mA	
Supply ripple		-	-	10	mV _{P-P}	
Data output high			=>4.5		V	
Data output low			<= 0.5		V	
RF						
RF sensitivity			-107		DBm	
IF Bandwidth			40		KHz	
Initial frequency accuracy			1		KHz	
Max R.F. input			-20		DBm	
E.M.C.						
Spurious responses upto 1GHz			36		dB	
LO leakage, conducted			57		dBm	
LO leakage, radiated			57		dBm	
DYNAMIC TIMING						
Power up to stable data <i>(With RF signal present)</i>			5		mS	
Signal to stable data <i>(With power supply already on)</i>			3		mS	
Mark:space ratio			50		%	
Bit rate		20		20000	bps	

Transmitter Connection Diagram

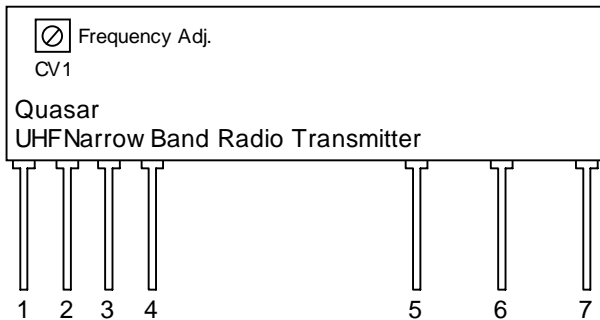

Figure 1: Narrow Band Transmitter

Receiver Connection Diagram

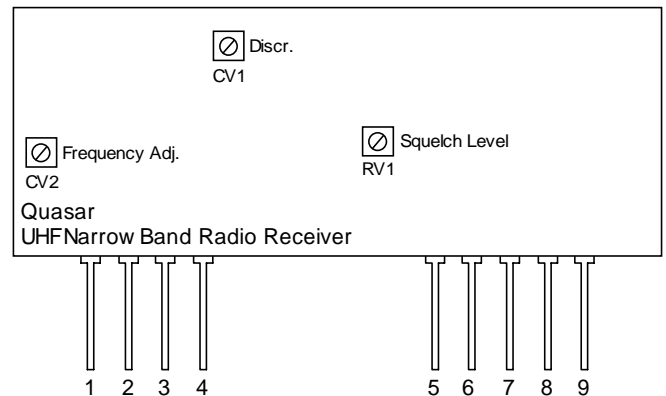

Figure 2: Narrow Band Receiver

Pin Description:

GND (pin 1)

Ground connection, connected to pins 4 and 5.

MODULATION INPUT (pin 2)

A digital data signal (0-5V) or an analogue signal (3V_{p-p}) directly coupled with a 0.1 – 0.22µF capacitor must be directly connected to this pin. A 1st order low-pass filter is used internally and so there is a resulting frequency deviation of ±7 KHz. **Note:** a DC bias of 2.5 V is present on this pin. CV1 must be adjusted to obtain the centre channel frequency with the modulation input terminal disconnected.

UNCONNECTED (pin 3)

Extra SIL pin for additional mechanical retention.

GND (pin 4)

Ground connection, connected to pins 1 and 5.

GND (pin 5)

Ground connection, connected to pins 1 and 4

RF OUT (pin 6)

Antenna output

V_{CC} (pin 7)

+Ve supply pin. Operation from a 5V supply able to source 22mA.

Pin Description:

V_{CC} (pin 1)

+Ve supply pin. Operation from a 5V supply able to source 14mA. Connected to pin 9.

GND (pin 2)

Ground connection, connected to pins 4 and 5.

RF IN (pin 3)

Antenna input.

GND (pin 4)

Ground connection, connected to pins 2 and 5.

GND (pin 5)

Ground connection, connected to pins 2 and 4.

RSSI (pin 6)

The Received Signal Strength Indicator provides a DC output voltage proportional to the RF input signal

AF OUT (pin 7)

Analogue signal output. A 100nF series capacitor is required.

DATA OUT (pin 8)

CMOS compatible output. This may be used to drive external decoders.

V_{CC} (pin 9)

+Ve supply pin. Operation from a 5V supply able to source 14mA. Connected to pin 1.

General Information

Functional Description

The QBT37-XXX FM narrow band transmitter module consists of a low frequency directly modulated crystal oscillator and multiplier and filter circuits. Baseband data directly modulates the low frequency crystal oscillator, the output of which is applied to the first of three frequency multipliers to achieve the final output frequency after being processed by interstage band pass filter circuits.

The QBR37-XXX FM narrow band receiver module uses the single conversion super-het principle. The applied RF signal is amplified and applied to the RF mixer. Using a 10.7 MHz IF frequency at 50KHz channel spacing enables use of ceramic filters to provide good adjacent channel rejection. Baseband demodulation is recovered from this IF and applied to a squelch circuit. Therefore, data is only available when a RF signal is present.

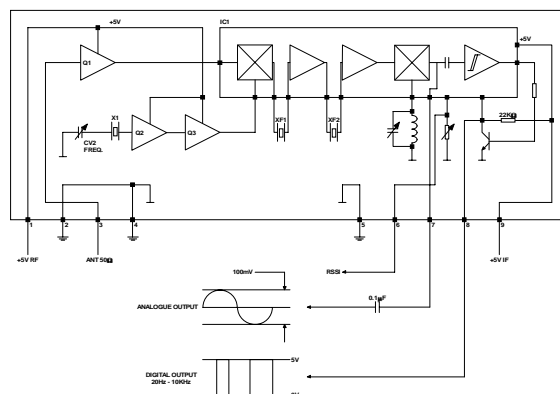
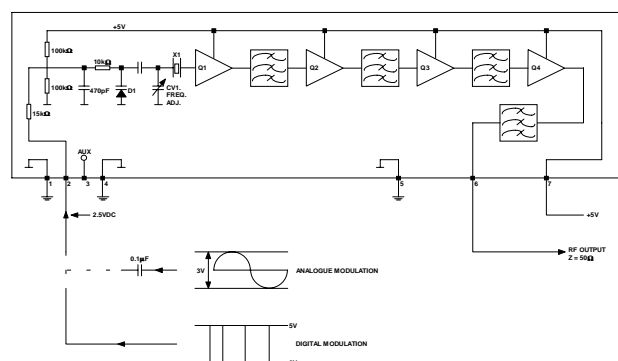

Figure 3: Narrow Band Transmitter and Receiver Block Diagrams

Frequency Channels

The QBT37-XXX and QBR37-XXX are available in 34 discrete frequency channels from 433.075 to 434.725 MHz in 50KHz steps. The table below shows the list of possible frequency channels.

CH.	FREQ/MHz	CH.	FREQ/MHz
1	433.075	18	433.925
2	433.125	19	433.975
3	433.175	20	434.025
4	433.225	21	434.075 (1)
5	433.275	22	434.125
6	433.325	23	434.175
7	433.375	24	434.225
8	433.425	25	434.275
9	433.475	26	434.325 (1)
10	433.525	27	434.375
11	433.575	28	434.425
12	433.625	29	434.475
13	433.675	30	434.525 (1)
14	433.725	31	434.575
15	433.775	32	434.625
16	433.825	33	434.675
17	433.875	34	434.725

(1) Stock Item

Mechanical Dimensions

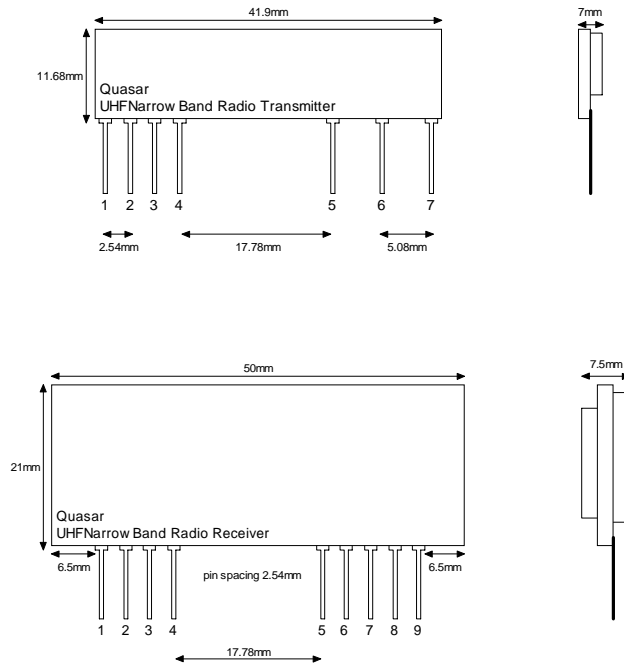

Figure 6: FM Narrow Band Transmitter and Receiver

Ordering Information

Standard Product;

Part No	Description
QBT37-434.075	SIL Narrow Band Transmitter
QBT37-434.325	SIL Narrow Band Transmitter
QBT37-434.525	SIL Narrow Band Transmitter
QBR37-434.075	SIL Narrow Band Receiver
QBR37-434.325	SIL Narrow Band Receiver
QBR37-434.525	SIL Narrow Band Receiver

Custom Product;

Any frequency between 433.075MHz – 434.725MHz is available in steps of 50KHz.

This gives 34 channels of module possibility.

Please consult our sales department for further information.